

LOC	DIST	P	LTR	REVISIONS	DATE	DWN	APVD
				ÄNDERUNGEN			
				BESCHREIBUNG			
A1	-	-	-	SEE SHEET 1	-	-	-
PROJECT NO.: EGG102008							

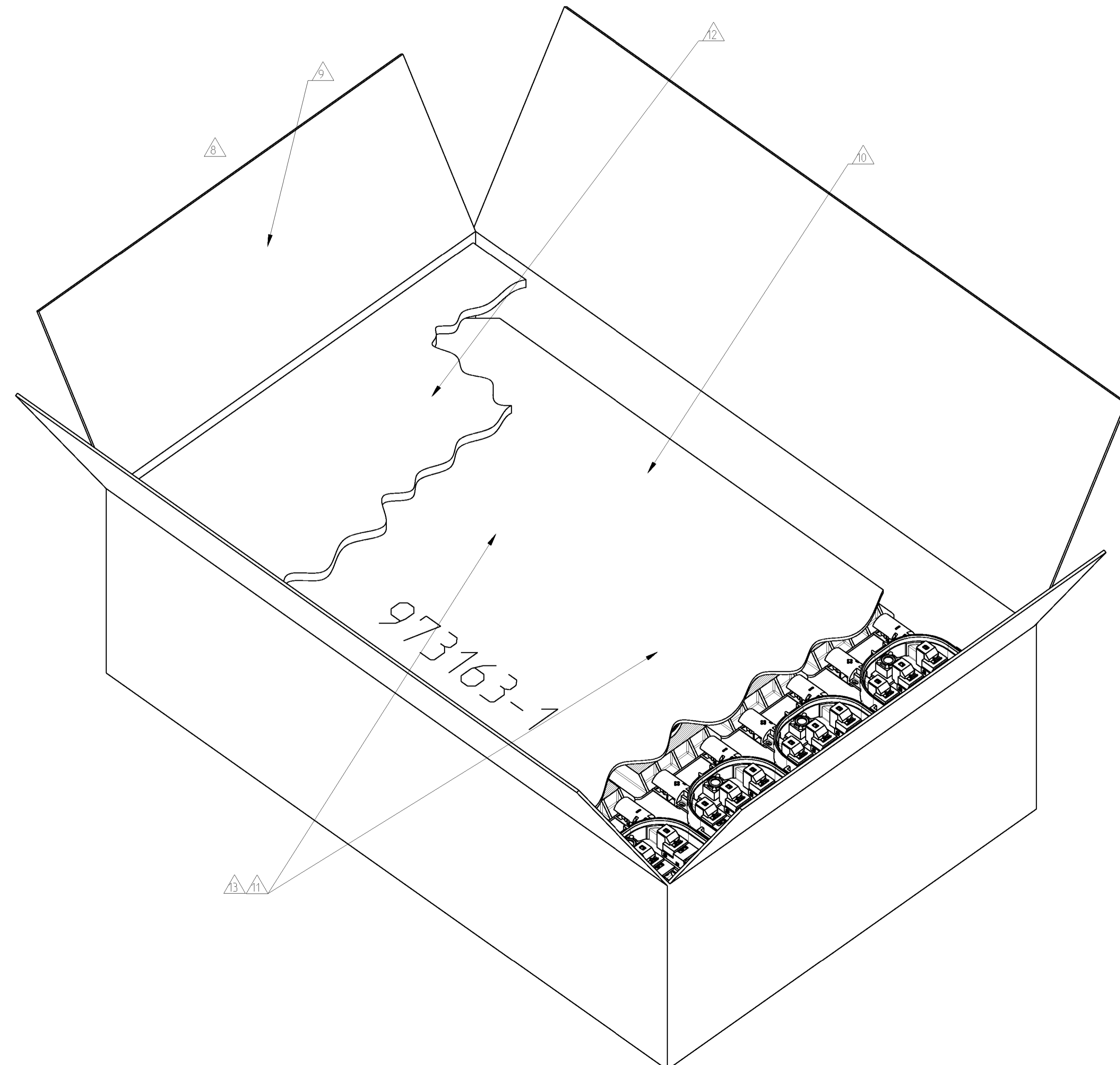

△ **PACKAGING:** 80 PIECES SOLAR MODULE BOX ASSY'S PACKAGED IN CORRUGATED SHIPPING BOX △
 PER AMP-SPEC. 107-18052.
 5 LAYERS OF 16 PIECES.
 USED CORRUGATED LAYER PAD FOR INTERLAYER.
 FIFTH LAYER SOLAR MODULE BOX ASSY'S COVERED WITH CORRUGATED LAYER PAD △.
 80 PIECES SOLAR MODULE BOX COVER ASSY'S ITEM NO. 1 OF 40 PIECES BULK PACKAGED
 IN PLASTIC BAG △ PUT ON THE FIFTH LAYER CORRUGATED LAYER PAD △.
 ON TOP USED AS COVER PAPER CUSHION △.

PACKAGING UNIT: 80 PIECES
MINIMUM ORDER QUANTITY: 80 PIECES

△ SOLAR MODULE BOX COVER ASSY'S ITEM NO. 1 PACKAGED IN PLASTIC BAG NOT SHOWN.

△ **VERPACKUNG:** 80 STÜCK SOLAR MODUL BOX ASSY'S VERPACKT IN VERSANDKARTON △
 NACH AMP-SPEZ. 107-18052.
 5 LAGEN ZU JE 16 STÜCK.
 ZWISCHENLAGENWELLPAPIER ALS ZWISCHENLAGE VERWENDET.
 FÜNFTE LAGE SOLAR MODUL BOX ASSY'S MIT ZWISCHENLAGENWELLPAPIER △ ABGEDECKT.
 80 STÜCK SOLAR MODUL BOX DECKEL ASSY'S ITEM NO. 1 ZU JE 40 STÜCK ALS SCHÜTTGUT
 IN KUNSTSTOFF-BEUTEL VERPACKT △ AUF DIE FÜNFTE LAGE ZWISCHENLAGENWELLPAPIER △ GELEGT.
 OBENAUF PAPIERPOLSTER △ ALS ABDECKUNG VERWENDET.

VERPACKUNGSEINHEIT: 80 STÜCK
MINDESTBESTELLMENGE: 80 STÜCK

△ SOLAR MODUL BOX DECKEL ASSY'S ITEM NO. 1 VERPACKT IN KUNSTSTOFF-BEUTEL NICHT DARGESTELLT.

DIMENSIONS MASSENEHLEN (MM)		TOLERANCES UNLESS OTHERWISE SPECIFIED: ALL DIMENSIONS		DWN E. WERNER 28-JUL-03	tyco Electronics AMP GmbH D - 64625 Bensheim
		0 PLC ± 1 PLC ± 2 PLC ± 3 PLC ± 4 PLC ±		DATE 28-JUL-03	NAME SOLARLOK PLUS R 4 A SOLARLOK PLUS R 4 A
MATERIAL -		FINISH/BOHRENFARBE -		APVD E. FELDMEIER 28-JUL-03	
PRODUCT SPEC 107-18052		APPLICATION SPEC 114-18488		CAGE CODE 00779	DRAWING NO. 1418867-1
WEIGHT -		CUSTOMER DRAWING		SCALE 5:1	SHEET 2 OF 2
RESTRICTED TO MR PER		REV 01		DATE -	

LOC	DIST	REV	DATE	BY	APPV
A1	-	A1	28-JUL-03	EW	GF
		B1	10-AUG-04	EW	GF
		C1	23-FEB-05	EW	GF
		D1	30SEP2005	SH	GF

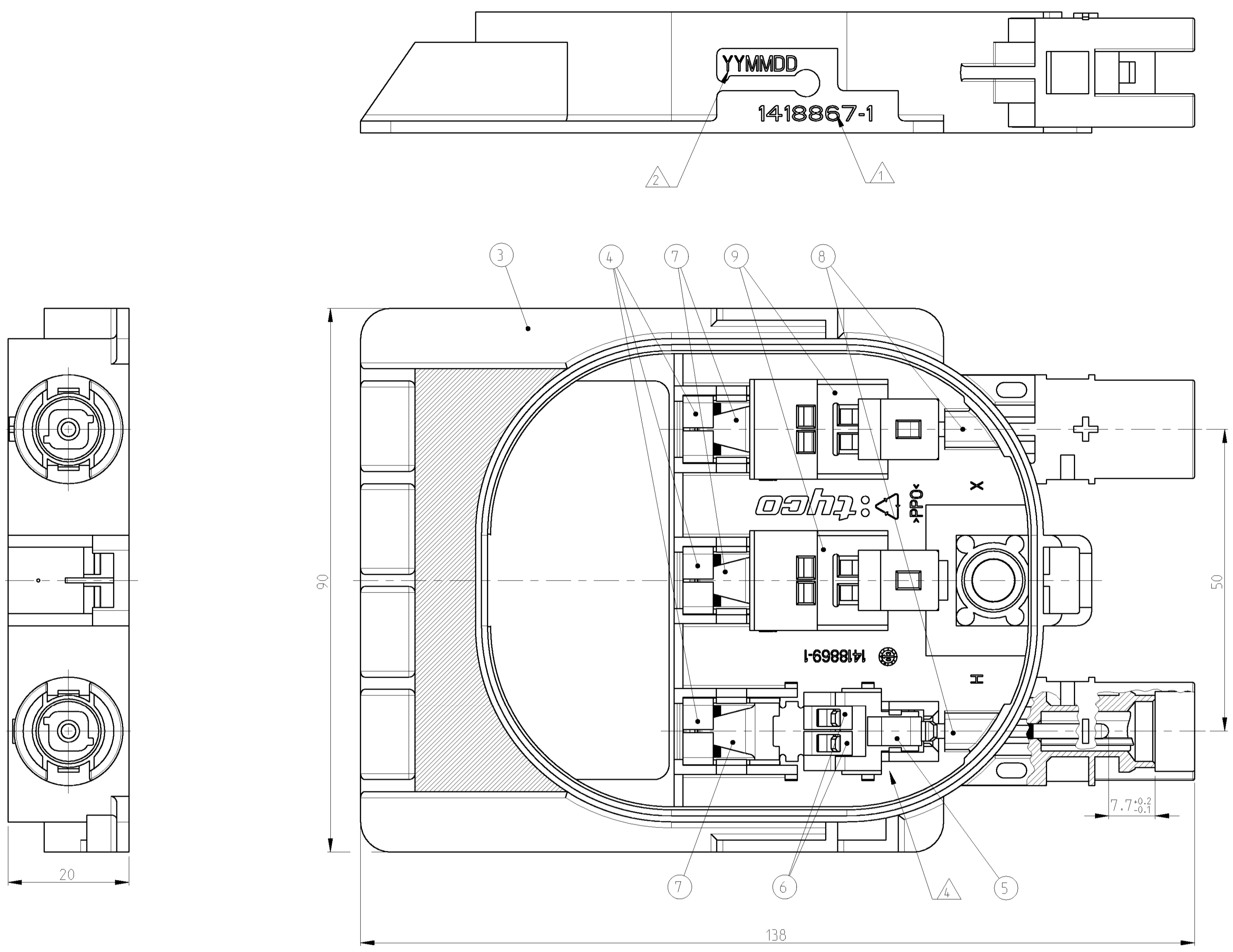

- △ PART NUMBER, WITH PREFIX - AND SUFFIX NUMBER
- △ PRODUCTION DATE (YYMMDD)
- △ COVER ITEM NO. 1 AND O-RING ITEM NO. 2 NOT SHOWN. COVER NOT ASSEMBLED WITH LOWER PART. ENCLOSE LOOSELY
- △ SHROUDING COVER ITEM NO. 9 NOT SHOWN
- 5 TOTAL HEIGHT WITH CLOSED COVER 22.5mm

- △ TEILENUMMER, MIT VOR- UND NACHSTRICHAHL
- △ FERTIGUNGSDATUM (YYMMDD)
- △ DECKEL ITEM NO. 1 UND O-RING ITEM NO. 2 NICHT DARGESTELLT. DECKEL NICHT MIT UNTERTEIL MONTIERT. LOSE BEIGELEGT.
- △ ABDECKHAUBE ITEM NO. 9 NICHT DARGESTELLT
- 5 GESAMTHÖHE MIT GESCHLOSSENEM DECKEL 22.5mm

VIEW WITH ASSEMBLED COVER
 ANSICHT MIT MONTIERTEM DECKEL

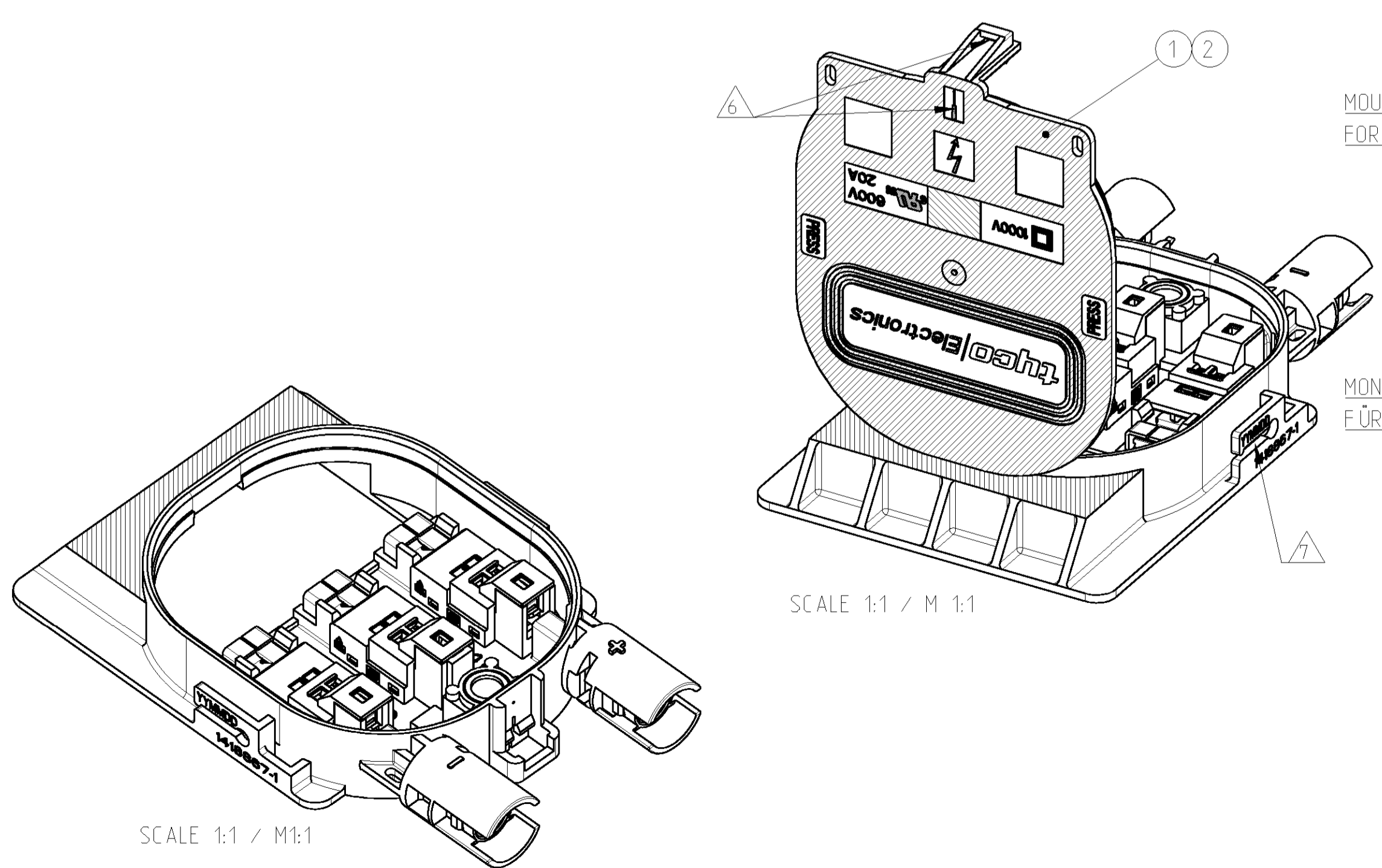

MOUNTING INSTRUCTION FOR COVER, ASSY:
 1. MOUNT COVER ITEM NO. 1 AND 2 INTO THE LOWER PART ITEM NO. 3 AND CLOSE IT. (LATCH SNAP IN).
 2. RE-OPEN: PUT IN MARKED OPENING △ SCREWDRIVER 3mm AND MOVE LATCH UNTIL LOCKING LATCH FREE THE COVER. OPEN COVER ITEM NO. 1 AND 2 AND PUT IN LATERAL RETAINING SLOT △ .

MONTAGEANWEISUNG FÜR DECKEL, ASSY:
 1. DECKEL ITEM NO. 1 UND 2 IN DAS UNTERTEIL ITEM NO. 3 EINHÄNGEN UND SCHLIESSEN. (LASCHE RASTET EIN).
 2. ÖFFNEN: SCHRAUBENDREHER 3mm IN MARKIERTE ÖFFNUNG △ EINSTECKEN UND LASCHE BEWEGEN BIS RASTHAKEN DEN DECKEL FREI GIBT. DECKEL ITEM NO. 1 UND 2 ÖFFNEN UND IN SEITLICHEN HALTESCHLITZ △ EINSETZEN.

-1 AS SHOWN
 -1 WIE GEZEICHNET

ITEM-NO.	QTY.	DESCRIPTION	SURFACE	MATERIAL
ORDER NO.	POS.	BESTELL-NR.	COLOUR/FARBE	
9	3	SHROUDING COVER ABDECKHAUBE	BLACK SCHWARZ	PEI PEI
8	2	CONTACT PIN KONTAKTSTIFT	Ag	CuZn
7	3	FOIL SPRING FOLIENFEDER	PLAIN BLANK	STAINLESS STEEL ROSTFREIER STAHL
6	6	AMP SPRING CLAMP WITH ANTI OVERSTRESS AMP-KAFIGZUGFEDER MIT OBERBEHNSCHUTZ	PLAIN BLANK	STAINLESS STEEL ROSTFREIER STAHL
5	2	AMP SPRING CLAMP WITH ANTI OVERSTRESS AMP-KAFIGZUGFEDER MIT OBERBEHNSCHUTZ	PLAIN BLANK	STAINLESS STEEL ROSTFREIER STAHL
4	3	CONTACT RAIL STRÖMSCHIENE	TIN HOT DIPPED FEUERVERZINNT	CuSn CuSn
3	1	SOLAR MODULE BOX, LOWER PART ASSY SOLAR MODUL BOX, UNTERTEIL ASSY	BLACK SCHWARZ	-
2	1	O-RING	RED ROT	SILICONE SILIKON
1	1	SOLAR MODULE BOX COVER SOLAR MODUL BOX DECKEL	BLACK SCHWARZ	PPD

TYCO	ITEM-NO.	QTY.	DESCRIPTION	SURFACE	MATERIAL
ORDER NO.	POS.	STK.	BENENNUNG	COLOUR/FARBE	
1418867-1					

TYCO	ITEM-NO.	QTY.	DESCRIPTION	SURFACE	MATERIAL
ORDER NO.	POS.	STK.	BENENNUNG	COLOUR/FARBE	
1418867-1					

TYCO	ITEM-NO.	QTY.	DESCRIPTION	SURFACE	MATERIAL
ORDER NO.	POS.	STK.	BENENNUNG	COLOUR/FARBE	
1418867-1					

TYCO	ITEM-NO.	QTY.	DESCRIPTION	SURFACE	MATERIAL
ORDER NO.	POS.	STK.	BENENNUNG	COLOUR/FARBE	
1418867-1					

TYCO	ITEM-NO.	QTY.	DESCRIPTION	SURFACE	MATERIAL
ORDER NO.	POS.	STK.	BENENNUNG	COLOUR/FARBE	
1418867-1					

TYCO	ITEM-NO.	QTY.	DESCRIPTION	SURFACE	MATERIAL
ORDER NO.	POS.	STK.	BENENNUNG	COLOUR/FARBE	
1418867-1					

TYCO	ITEM-NO.	QTY.	DESCRIPTION	SURFACE	MATERIAL
ORDER NO.	POS.	STK.	BENENNUNG	COLOUR/FARBE	
1418867-1					

TYCO	ITEM-NO.	QTY.	DESCRIPTION	SURFACE	MATERIAL
ORDER NO.	POS.	STK.	BENENNUNG	COLOUR/FARBE	
1418867-1					

TYCO	ITEM-NO.	QTY.	DESCRIPTION	SURFACE	MATERIAL
ORDER NO.	POS.	STK.	BENENNUNG	COLOUR/FARBE	
1418867-1					

TYCO	ITEM-NO.	QTY.	DESCRIPTION	SURFACE	MATERIAL
ORDER NO.	POS.	STK.	BENENNUNG	COLOUR/FARBE	
1418867-1					

TYCO	ITEM-NO.	QTY.	DESCRIPTION	SURFACE	MATERIAL
ORDER NO.	POS.	STK.	BENENNUNG	COLOUR/FARBE	
1418867-1					

TYCO	ITEM-NO.	QTY.	DESCRIPTION	SURFACE	MATERIAL
ORDER NO.	POS.	STK.	BENENNUNG	COLOUR/FARBE	
1418867-1					

TYCO	ITEM-NO.	QTY.	DESCRIPTION	SURFACE	MATERIAL
ORDER NO.	POS.	STK.	BENENNUNG	COLOUR/FARBE	
1418867-1					

TYCO	ITEM-NO.	QTY.	DESCRIPTION	SURFACE	MATERIAL
ORDER NO.	POS.	STK.	BENENNUNG	COLOUR/FARBE	
1418867-1					

TYCO	ITEM-NO.	QTY.	DESCRIPTION	SURFACE	MATERIAL
ORDER NO.	POS.	STK.	BENENNUNG	COLOUR/FARBE	
1418867-1					

TYCO	ITEM-NO.	QTY.	DESCRIPTION	SURFACE	MATERIAL
ORDER NO.	POS.	STK.	BENENNUNG	COLOUR/FARBE	
1418867-1					

TYCO	ITEM-NO.	QTY.	DESCRIPTION	SURFACE	MATERIAL
ORDER NO.	POS.	STK.	BENENNUNG	COLOUR/FARBE	
1418867-1					

TYCO	ITEM-NO.	QTY.	DESCRIPTION	SURFACE	MATERIAL
ORDER NO.	POS.	STK.	BENENNUNG	COLOUR/FARBE	
1418867-1					

TYCO	ITEM-NO.	QTY.	DESCRIPTION	SURFACE	MATERIAL
ORDER NO.	POS.	STK.	BENENNUNG	COLOUR/FARBE	
1418867-1					

TYCO	ITEM-NO.	QTY.	DESCRIPTION	SURFACE	MATERIAL
ORDER NO.	POS.	STK.	BENENNUNG	COLOUR/FARBE	
1418867-1					

TYCO	ITEM-NO.	QTY.	DESCRIPTION	SURFACE	MATERIAL
ORDER NO.	POS.	STK.	BENENNUNG	COLOUR/FARBE	
1418867-1					

TYCO	ITEM-NO.	QTY.	DESCRIPTION	SURFACE	MATERIAL
ORDER NO.	POS.	STK.	BENENNUNG	COLOUR/FARBE	
1418867-1					

TYCO	ITEM-NO.	QTY.	DESCRIPTION	SURFACE	MATERIAL
ORDER NO.	POS.	STK.	BENENNUNG	COLOUR/FARBE	
1418867-1					

TYCO	ITEM-NO.	QTY.	DESCRIPTION	SURFACE	MATERIAL
ORDER NO.	POS.	STK.	BENENNUNG	COLOUR/FARBE	
1418867-1					

TYCO	ITEM-NO.	QTY.	DESCRIPTION	SURFACE	MATERIAL
ORDER NO.	POS.	STK.	BENENNUNG	COLOUR/FARBE	
1418867-1					

TYCO	ITEM-NO.	QTY.	DESCRIPTION	SURFACE	MATERIAL
ORDER NO.	POS.	STK.	BENENNUNG	COLOUR/FARBE	
1418867-1					

TYCO	ITEM-NO.	QTY.	DESCRIPTION	SURFACE	MATERIAL
ORDER NO.	POS.	STK.	BENENNUNG	COLOUR/FARBE	
1418867-1					

TYCO	ITEM-NO.	QTY.	DESCRIPTION	SURFACE	MATERIAL
ORDER NO.	POS.	STK.	BENENNUNG	COLOUR/FARBE	
1418867-1					

TYCO	ITEM-NO.	QTY.	DESCRIPTION	SURFACE	MATERIAL
ORDER NO.	POS.	STK.	BENENNUNG	COLOUR/FARBE	
1418867-1					

TYCO	ITEM-NO.	QTY.	DESCRIPTION	SURFACE	MATERIAL
ORDER NO.	POS.	STK.	BENENNUNG	COLOUR/FARBE	
1418867-1					

TYCO	ITEM-NO.	QTY.	DESCRIPTION	SURFACE	MATERIAL
ORDER NO.	POS.	STK.	BENENNUNG	COLOUR/FARBE	
1418867-1					

TYCO	ITEM-NO.	QTY.	DESCRIPTION	SURFACE	MATERIAL
ORDER NO.	POS.	STK.	BENENNUNG	COLOUR/FARBE	
1418867-1					

TYCO	ITEM-NO.	QTY.	DESCRIPTION	SURFACE	MATERIAL
ORDER NO.	POS.	STK.	BENENNUNG	COLOUR/FARBE	
1418867-1					

TYCO	ITEM-NO.	QTY.	DESCRIPTION	SURFACE	MATERIAL
ORDER NO.	POS.	STK.	BENENNUNG	COLOUR/FARBE	
1418867-1					

TYCO	ITEM-NO.	QTY.	DESCRIPTION	SURFACE	MATERIAL
ORDER NO.	POS.	STK.	BENENNUNG	COLOUR/FARBE	
1418867-1					

TYCO	ITEM-NO.	QTY.	DESCRIPTION	SURFACE	MATERIAL
ORDER NO.	POS.	STK.	BENENNUNG	COLOUR/FARBE	
1418867-1					

TYCO	ITEM-NO.	QTY.	DESCRIPTION	SURFACE	MATERIAL
ORDER NO.	POS.	STK.	BENENNUNG	COLOUR/FARBE	
1418867-1					

TYCO	ITEM-NO.	QTY.	DESCRIPTION	SURFACE	MATERIAL
ORDER NO.	POS.	STK.	BENENNUNG	COLOUR/FARBE	
1418867-1					

TYCO	ITEM-NO.	QTY.	DESCRIPTION	SURFACE	MATERIAL
ORDER NO.	POS.	STK.	BENENNUNG	COLOUR/FARBE	
1418867-1					

TYCO	ITEM-NO.	QTY.	DESCRIPTION	SURFACE	MATERIAL
ORDER NO.	POS.	STK.	BENENNUNG	COLOUR/FARBE	
1418867-1					

TYCO	ITEM-NO.	QTY.	DESCRIPTION	SURFACE	MATERIAL
ORDER NO.	POS.	STK.	BENENNUNG	COLOUR/FARBE	
1418867-1					

TYCO	ITEM-NO.	QTY.	DESCRIPTION	SURFACE	MATERIAL
ORDER NO.	POS.	STK.	BENENNUNG	COLOUR/FARBE	
1418867-1					

TYCO	ITEM-NO.	QTY.	DESCRIPTION	SURFACE	MATERIAL
ORDER NO.	POS.	STK.	BENENNUNG	COLOUR/FARBE	
1418867-1					

TYCO	ITEM-NO.	QTY.	DESCRIPTION	SURFACE	MATERIAL
ORDER NO.	POS.	STK.	BENENNUNG	COLOUR/FARBE	
1418867-1					

TYCO	ITEM-NO.	QTY.	DESCRIPTION	SURFACE	MATERIAL
ORDER NO.	POS.	STK.	BENENNUNG	COLOUR/FARBE	
1418867-1					

TYCO	ITEM-NO.	QTY.	DESCRIPTION	SURFACE	MATERIAL
ORDER NO.	POS.	STK.	BENENNUNG	COLOUR/FARBE	
1418867-1					

TYCO	ITEM-NO.	QTY.	DESCRIPTION	SURFACE	MATERIAL
ORDER NO.	POS.	STK.	BENENNUNG	COLOUR/FARBE	
1418867-1					

TYCO	ITEM-NO.	QTY.	DESCRIPTION	SURFACE	MATERIAL
ORDER NO.	POS.	STK.	BENENNUNG	COLOUR/FARBE	
1418867-1					

TYCO	ITEM-NO.	QTY.	DESCRIPTION	SURFACE	MATERIAL
ORDER NO.	POS.	STK.	BENENNUNG	COLOUR/FARBE	
1418867-1					

TYCO	ITEM-NO.	QTY.	DESCRIPTION	SURFACE	MATERIAL
ORDER NO.	POS.	STK.	BENENNUNG	COLOUR/FARBE	
1418867-1					

TYCO	ITEM-NO.	QTY.	DESCRIPTION	SURFACE	MATERIAL
ORDER NO.	POS.	STK.	BENENNUNG	COLOUR/FARBE	
1418867-1					

TYCO	ITEM-NO.	QTY.	DESCRIPTION	SURFACE	MATERIAL
ORDER NO.	POS.	STK.	BENENNUNG	COLOUR/FARBE	
1418867-1					

TYCO	ITEM-NO.	QTY.	DESCRIPTION	SURFACE	MATERIAL
ORDER NO.	POS.	STK.	BENENNUNG	COLOUR/FARBE	
1418867-1					

TYCO	ITEM-NO.	QTY.	DESCRIPTION	SURFACE	MATERIAL
ORDER NO.	POS.	STK.	BENENNUNG	COLOUR/FARBE	
1418867-1					

TYCO	ITEM-NO.	QTY.	DESCRIPTION	SURFACE	MATERIAL
ORDER NO.	POS				